

PWR, SF, BF, MT,
LINK 1, ACT 1, LINK
2, and ACT 2 LEDs

Ethernet Ports

Power
Supply
LED

Door for Micro USB Port

PROFINET Scanner

The EPXPNS101 PROFINET Scanner is a PROFINET I/O device supporting S-1 PROFINET Simplex and S-2 PROFINET System redundancy. The network adapter is the head module for the RSTi-EP system bus, to which up to 64 active RSTi-EP modules can be connected. The PROFINET network adapter has two Ethernet ports, and an integrated switch.

The PROFINET Scanner can be accessed with a system-independent web server application via the USB service interface or the Ethernet. Thus, all information, such as diagnostics, status values and parameters, can be read and all connected modules can be simulated or forced.

The station's main power supply is integrated in the PROFINET Scanner. Power is supplied via two 4-pole connectors, separated into the input and output current paths.

Caution, the RSTi-EP station is usually installed on a horizontally positioned DIN rail. Installation on vertically positioned DIN rails is also possible. However, the heat dissipation is reduced such that the derating values change (refer to the section, [Thermal Derating](#)).

Modules should to be allowed to de-energize for a minimum 10 seconds after power down, prior to starting any maintenance activity. The PROFINET Scanner cannot be hot-swapped.

Refer to the *RSTi-EP Slice I/O User Manual* (GFK-2958) for additional information.

Refer to the *RSTi-EP Power Supply Reference Guide*, a software utility available on PME V9.00, for detailed power-feed requirements.

Module Features

- Supports up to 64 active RSTi-EP modules
- Supports PROFINET RT (only) for Redundancy and Non Redundancy mode
- *Spring-style* technology for ease of wiring
- DIN rail mounted
- Double-click installation for positive indication of correct installation
- Built-in Web Server (HTTP & HTTPS) for diagnostic information and firmware update through Ethernet and micro USB port
- Supports Type S2 System Redundancy operation
- Supports Media Redundancy Protocol (MRP) Client mode operation
- Support for daisy-chain/line, star, or ring (MRP) technologies
- Two switched Ethernet ports; 8-conductor RJ-45 shielded twisted pair 10/100 Mbps copper interfaces
- Fast start-up < 500 ms with a maximum of 10 modules

GFK-3052

Ordering Information

Module	Description
EPXPNS101	RSTi-EP Slice I/O PROFINET Network Adapter 2CU RJ45 PORTS

Specifications

		EPXPNS101	
System data			
Connection	2 x RJ-45		
Fieldbus protocol	PROFINET Version 2.3 Class C I/O Device (RT Only)		
PROFINET System Redundancy Support	Redundantly controlled operation conforms to PROFINET V2.3 Type S-2 System Redundancy		
Application Relations Supported	1 Simplex AR or 1 SR-AR set made of 2 SR-ARs		
Number of Application Relations Supported	1 Simplex AR or 1 SR-AR set made of 2 SR-ARs		
Process image	Input data width	max. 512 bytes	
	Output data width	max. 512 bytes	
	Parameter data	max. 4362 bytes	
	Diagnostic data	max. 1408 bytes	
Number of modules	max. 64 active		
Configuration interface	Micro USB 2.0		
Transfer rate	Fieldbus	Max. 100 Mbps	
	RTSi-EP system bus	Max. 48 Mbps	
Data format	Default: Motorola	Configurable: Intel	
Status Bits	16 Input Status Bits		
PROFINET I/O Update Rate	Configurable selections: 1ms, 2ms, 4ms, 8ms, 16ms, 32ms, 64ms, 128ms, 256ms and 512ms		
Supports MRP	Yes * [Min I/O Update Rate for bumpless operation in an MRP ring topology 128ms for Profinet System Redundancy configuration. For simplex system Min IO update rate for MRP bumpless operation is 8ms]		
Supply			
Supply voltage for system and inputs	20.4V – 28.8V		
Supply voltage for outputs	20.4V – 28.8V		
Max. feed-in current for input modules	10 A		
Max. feed-in current for output modules	10 A		
Current consumption from system current path I _{sys}	116 mA		
Connection data			
Type of connection	Spring style		
Conductor cross-section	Single-wired, fine-wired	0.14 – 1.5 mm ² (AWG 26 – 16)	
General data			
Operating temperature	-20°C to +60°C (-4 °F to +140 °F)		
Storage temperature	-40°C to +85°C (-40 °F to +185 °F)		
Air humidity (operation/transport)	5% to 95%, noncondensing as per DIN EN 61131-2		
Width	52 mm (2.05 in)		
Depth	76 mm (2.99 in)		
Height	120 mm (4.72 in)		
Weight	220 g (7.76 oz)		
Configuration	V2.3 GSDML file is available on the Support website http://support.ge-ip.com for download and import into Proficy Machine Edition. The GSDML supporting a firmware release is part of the firmware upgrade kit available on the Support website.		

For public disclosure

LEDs

LED Status Indicators

LED	Indication	LED State/Description
PWR	Power LED	Green: Supply voltage connected
SF	System fault	Red: Configuration error, or error in the PROFINET Scanner, or error in a module, or there is a new diagnostic report Red flashing: Station in Force mode
BF	Bus fault	Red: No connection to the fieldbus Red flashing: Configuration error, no connection to the control unit, or error in the parameter set
MT	Maintenance Required	Yellow: Error on the system bus or fieldbus
LINK 1	Connection	Green: Connection established between port 1 of the PROFINET Scanner and another field device
ACT 1	Active	Yellow flashing: Data being exchanged on port 1
LINK 2	Connection	Green: Connection established between port 2 of the PROFINET Scanner and another field device
ACT 2	Active	Yellow flashing: Data being exchanged on port 2

LED Indicators

LED	EPXPNS101
Power Supply	Green: Supply voltage > 18 V DC
	Red: At least one current path < 18 V
3.1	Green: Input current path supply voltage > 18 V DC
3.2	Red: Input current path supply voltage < 18 V DC
3.3	
3.4	Red: Internal fuse defective
4.1	Green: Output current path supply voltage > 18 V DC
4.2	Red: Output current path supply voltage < 18 V DC
4.3	
4.4	Red: Internal fuse defective

GFK-3052

Field Wiring

The connection frame has one connector, and two 24 V DC wires can be connected to each connector, along with two ground connections. Those four connectors are used as shown in the following figure. The *Spring style* technology allows either finely stranded or solid wire with crimped wire-end ferrules or ultrasonically welded wires, each with a maximum cross-section of 1.5 mm² (16 guage), to be inserted easily through the opening in the clamping terminal without having to use tools. To insert fine stranded wires without wire-end ferrules, the pusher must be pressed in with a screwdriver and released to latch the wire.

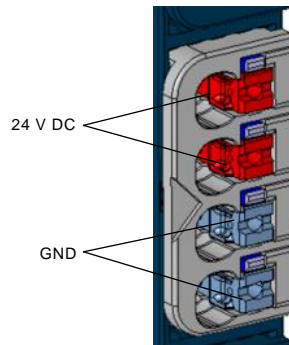

Connector Block

Connector Specifications:

- conductor cross-section 0.14 to 1.5 mm² (26 – 16 guage)
- max. ampacity: 10 A
- 4-pole

The modules do not have a fused sensor/activator power supply. All cables to the connected sensors/actuators must be fused corresponding to their conductor cross-sections (as per Standard DIN EN 60204-1, section 12).

Refer to the *RSTi-EP Slice I/O User Manual* (GFK-2958) for additional information.

For technical assistance, go to <http://support.ge-ip.com>.

Connection Diagrams

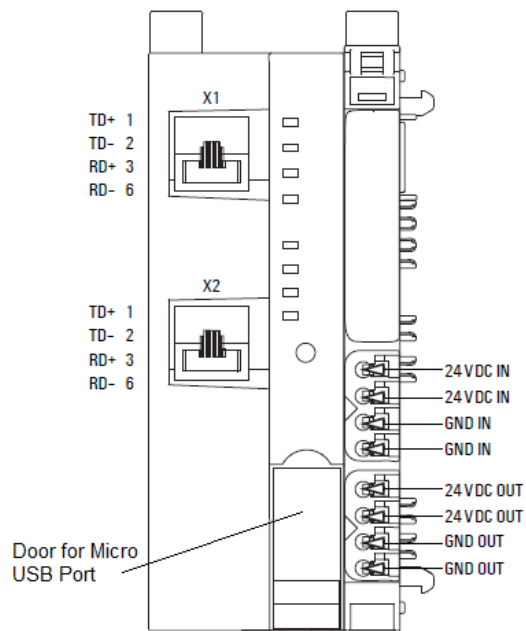

EPXPNS101

Connection Block Diagrams

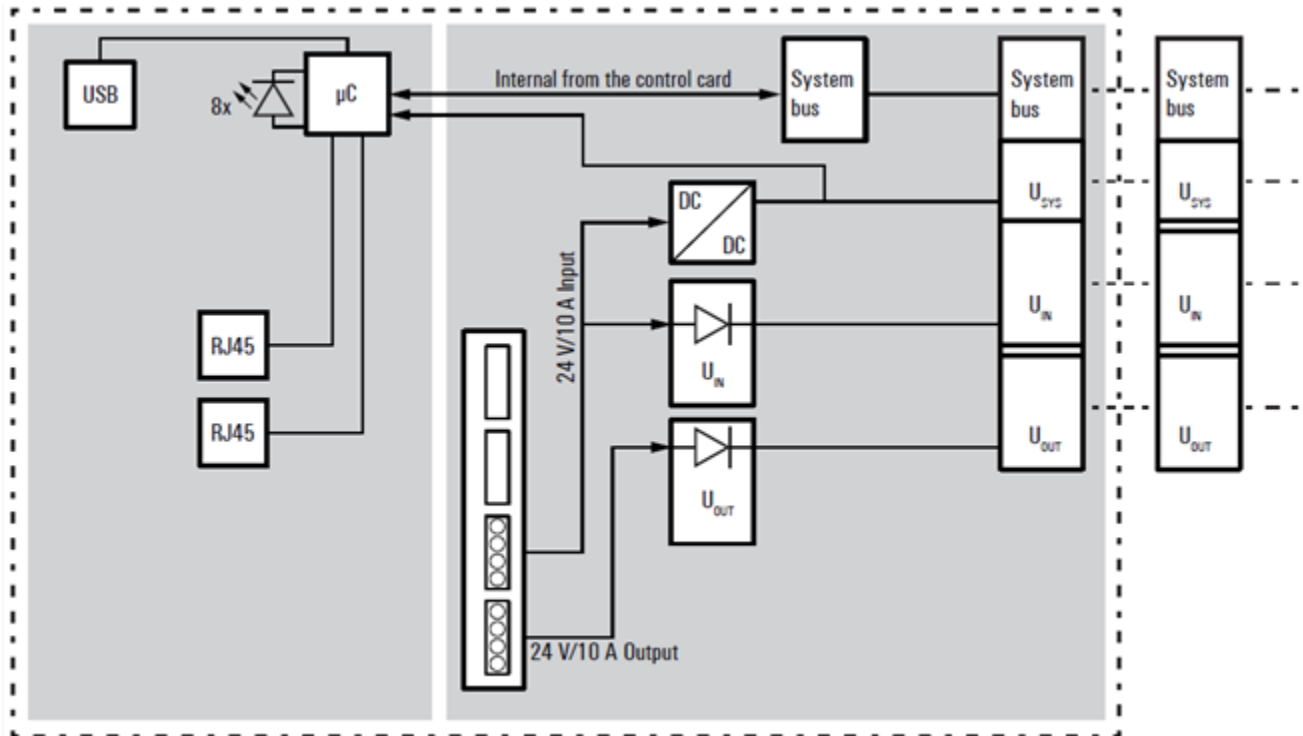



EPXPNS101

For public disclosure

GFK-3052

Installation in Hazardous Areas

- EQUIPMENT LABELED WITH REFERENCE TO CLASS I, GROUPS A, B, C & D, DIV. 2 HAZARDOUS AREAS IS SUITABLE FOR USE IN CLASS I, DIVISION 2, GROUPS A, B, C, D OR NON-HAZARDOUS AREAS ONLY
-  **WARNING - EXPLOSION HAZARD - SUBSTITUTION OF COMPONENTS MAY IMPAIR SUITABILITY FOR CLASS I, DIVISION 2;**
-  **WARNING - EXPLOSION HAZARD - WHEN IN HAZARDOUS AREAS, TURN OFF POWER BEFORE REPLACING OR WIRING MODULES; AND**
-  **WARNING - EXPLOSION HAZARD - DO NOT CONNECT OR DISCONNECT EQUIPMENT UNLESS POWER HAS BEEN SWITCHED OFF OR THE AREA IS KNOWN TO BE NONHAZARDOUS.**

ATEX Marking

 II 3 G Ex nA IIC T4 Gc

Ta: -20°C to +60°C (-4° F to +140 °F)

Thermal Derating

The power supply is restricted according to the temperature. The following values apply for the horizontal and vertical positioning of the RSTi-EP station:

Temperature-dependent Values for the Power Supply

	Horizontal	Vertical
Network adapter power supply	60°C (140 °F) : 2 x 8 A 55°C (131 °F) : 2 x 10 A	55°C (131 °F) : 2 x 6 A 50°C (122 °F) : 2 x 8 A
Power-feed module power supply	60°C (140 °F) : 1 x 10 A	55°C (131 °F) : 1 x 8 A

Refer to the *RSTi-EP Slice I/O Module User Manual* (GFK-2958) for additional information.

Supported Modules and Power Supplies

The following modules can be used with this release of the RSTi-EP PROFINET Network Adaptor :

Catalog Number	Module Description
Digital Input Modules	
EP-1214	Digital Input, 4 Points, Positive Logic 24VDC, 2,3, or 4 Wire
EP-1218	Digital Input, 8 Points, Positive Logic, 24VDC 2 Wire
EP-1318	Digital Input, 8 Points, Positive Logic, 24VDC 3 Wire
EP-125F	Digital Input, 16 Points, Positive Logic, 24VDC, 1 Wire
EP-12F4	Digital Input, 4 Points, Positive Logic 24VDC, 2,3, or 4 Wire, Time stamp
EP-1804	Digital Input, 4 Points 110/230 VAC (65 – 277 VAC), 2 Wire, Isolated
Digital Output Modules	
EP-2214	Digital Output, 4 Points, Positive Logic 24VDC, 0.5A, 2,3, or 4 Wire
EP-2614	Digital Output, 4 Points, Positive Logic 24VDC, 2.0A, 2,3, or 4 Wire
EP-2634	Digital Output, 4 Points, Positive/Negative Logic 24VDC, 2.0A, 2,3, or 4 Wire
EP-2218	Digital Output, 8 Points, Positive Logic, 24VDC, 0.5A, 2 Wire
EP-225F	Digital Input, 16 Points, Positive Logic, 24VDC, 0.5A, 1 Wire

Catalog Number	Module Description
Digital Relay Output Modules	
EP-2714	Digital Relay Output, 4 Points, Positive Logic, 24 - 220 VDC/VAC, 6A, 2 Wire
EP-2814	Solid-state Relay Output Module
Analog Input Modules	
EP-3164	Analog Input, 4 Channels Voltage/Current 16 Bits 2, 3, or 4 Wire
EP-3264	Analog Input, 4 Channels Voltage/Current 16 Bits with Diagnostics 2, 3, or 4 Wire
EP-3124	Analog Input, 4 Channels Voltage/Current 12 Bits 2, 3, or 4 Wire
EP-3368	Analog Input, 8 Channels Current 16 Bits 2, 3, or 4 Wire
EP-3468	Analog Input, 8 Channels Current 16 Bits 2, 3, or 4 Wire, Channel Diagnostic
EP-3704	Analog Input, 4 Channels RTD 16 Bits with Diagnostics 2, 3, or 4 Wire
EP-3804	Analog Input, 4 Channels TC 16 Bits with Diagnostics 2, 3, or 4 Wire
EP-3664	Analog Input, 4 Channels Voltage/Current 16 Bits with Diagnostics 2, 3, or 4 Wire, Differential Input
Analog Output Modules	
EP-4164	Analog Output, 4 Channels Voltage/Current 16 Bits 2, 3, or 4 Wire
EP-4264	Analog Output, 4 Channels Voltage/Current 16 Bits with Diagnostics 2, 3, or 4 Wire
Speciality Modules	
EP-5111	1 Channel High Speed Counter, AB 100 kHz 1 DO 24VDC, 0.5A
EP-5112	2 Channel High Speed Counter, AB 100 kHz
EP-5212	2 Channel Frequency Measurement, 100 kHz
EP-5261	1 Channel Serial Communications, 232, 422, 485
EP-5311	1 Channel SSI Encoder, BCD or Gray-Code Format, 5/24 VDC
EP-5422	2 Channels PWM Output, Positive Logic, 24VDC, 2.0 A
EP-5442	2 Channels PWM Output, Positive Logic, 24VDC, 0.5 A
Power Feed Modules for Input Current Path	
EP-7631	Power Module, 1 Channel 24VDC Input Flow 10A
Power Feed Modules for Output Current Path	
EP-7641	Power Module, 1 Channel 24VDC Output Flow 10A
Safe Feed-input Modules	
EP-1901	1 Safe Feed-Input, 24 VDC
EP-1902	2 Safe Feed-Inputs, 24 VDC, Programmable Delay
EP-1922	2 Safe Feed-Inputs, 24 VDC
Potential Distribution Modules	
EP-711F	Power Module, 16 Channels 24VDC Potential Distribution +24 VDC from Input Current Path
EP-751F	Power Module, 16 Channels 24VDC Potential Distribution +24 VDC from Output Current Path
EP-700F	Power Module, 16 Channels 24VDC Potential Distribution Functional Earth
EP-710F	Power Module, 16 Channels 24VDC Potential Distribution +0VDC from Input Current Path
EP-750F	Power Module, 16 Channels 24VDC Potential Distribution +0VDC from Output Current Path

GFK-3052

Release History

<i>Catalog Number</i>	<i>Firmware Version</i>	<i>Date</i>	<i>Comments</i>
EPXPNS101-AAAA	N/A	Sep-2018	Initial Release. This revision (and later) is usable in Marine Application and pass the Marine certification tests. Refer GFK-2958 for certification details.

Important Product Information for this Release

Updates

Documentation update for initial release

Functional Compatibility

N/A

Problems Resolved by this Release

None

New Features and Enhancements

None

Known Restrictions and Open Issues

Subject	Description
PNS behavior during MRP Ring Break with Lower Update rates	The recommended IO-Device Update Rate (ms) for the EPXPNS101 is 128 ms or higher, when used in MRP ring configuration to avoid momentary IO-Device disconnection and reconnection, in case of ring breaks. If the IO Update Rate is less than recommended, the IO-Device may disconnect and then re-connect momentarily causing loss of IO data when the MRP ring breaks.
Channel diagnostics faults are reported during hot-swap of the modules	During hot-swap of an I/O module, the network adapter may report additional channel diagnostics messages in addition to the expected <i>Loss of Module</i> or <i>Addition of Module</i> fault.
Behavior during hot removal when similar modules are configured consecutively	Where similar modules are configured consecutively in the remote I/O node, a shift in input data occurs when one of the consecutive modules is removed from the node. For example, when there are 6 RTD modules EP-3704, configured consecutively in the node, slots 1 - 6, on hot-removal of the module from slot 4, data from modules 5 and 6 would be reflected on variables configured for slots 4 and 5, respectively, with <i>Loss of Module</i> reported for slot 6.

Operational Notes

Subject	Description
PNIO Alarms behavior when RSTi-EP PNS is used with RX3i PNC/CPE330/CPE400	The PNIO alarms for the IO-Device do not show up in the "I/O Fault Table" of Proficy Machine Edition after PLC is started or Configuration is downloaded, even if the fault condition -like for e.g. open wire at channel etc. pre-exists. This is the behavior when RSTi-EP PNS is configured with RX3i PNC/CPE330/CPE400. However, once system is powered on, subsequent PNIO alarms from RSTi-EP PNS are logged in the "I/O Fault table" in Proficy Machine Edition appropriately during runtime.
Output behavior during hotswap	During hot insertion or removal of IO modules, a transient Loss of Power up-to 500 ms may occur on the network adapter and IO modules, during which all of the outputs may drop to zero. This system behavior should be verified against the application requirements before hot insertion or removal of the IO module is done.

Product Documentation

RSTi-EP Slice I/O Module User Manual (GFK-2958)

RSTi-EP Slice I/O Functional Safety Module User Manual (GFK-2956)

PACSystems* RX3i & RSTi-EP PROFINET IO-Controller User Manual (GFK-2571)

PACSystems* Hot Standby CPU Redundancy User Manual (GFK-2308)



<http://www.geautomation.com/>

For public disclosure